



**TRAILER
HITCHES**

Turnoverball™
GOOSENECK HITCH

Defender™
LOCKING GOOSENECK
COUPLER

5th Wheel Family
5TH WHEEL HITCHES

The Patriot 16K™
5TH WHEEL HITCH

Companion™
5TH WHEEL HITCH

Companion Slider™
5TH WHEEL HITCH

Tow & Stow
RECEIVER HITCH

4" Extender

Extend-A-Goose

16K Receiver Hitch

Hitch Balls

Ball Mounts

Pintle Plates

Cab Protector

Utility Rack



Your whole rig is riding on that hitch...
ever wonder who built it?

B&W Products

- 4 Turnoverball™
Gooseneck Hitch
- 6 Defender™
Locking Gooseneck Coupler
- 8 Short Bed Solutions
4" Extender
Extend-A-Goose
- 10 5th Wheel Family™
5th Wheel Hitches
- 12 The Patriot 16K™
5th Wheel Hitch
- 14 Companion™
5th Wheel Hitch
- 16 Companion Slider™
5th Wheel Hitch
- 18 Tow & Stow
Receiver Hitch
- 20 Receiver Hitches
- 21 Pintle Plates
- 21 Ball Mounts
- 21 Hitch Balls
- 22 Cab Protector
- 23 Utility Rack

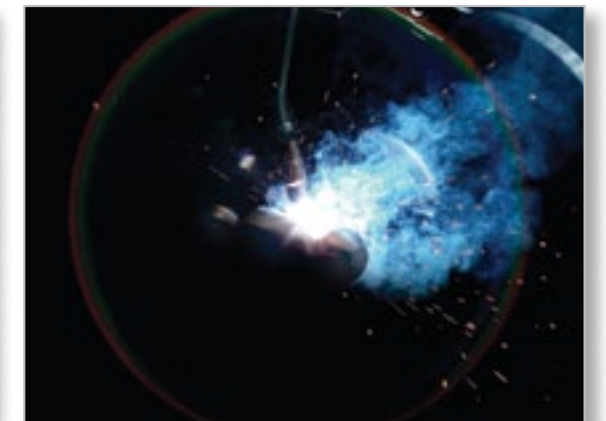

**B&W has been building
towing products you can
trust for twenty five years.**

Along the way we've also built a reputation for innovative design solutions executed with the highest quality workmanship and materials.

While our competitors may assemble foreign-bought parts in the US, a B&W hitch is built from start to finish in our state-of-the-art facility here in the heartland.

We utilize the latest computer controlled technology available, including robotic welding, but it takes more than equipment to build a B&W hitch. We truly believe that it's the skill and dedication of a craftsman that makes the difference in our products.

B&W is an employee owned company and everyone here has a stake in building a hitch you can count on.

Tow with confidence - Tow with B&W.





**A hitch
when you need it...
a level bed when you don't.**



Remove Ball



Turn Ball Over



Replace Ball In Socket

B&W Turnoverball™ Gooseneck Hitch

CONVERTS TO A LEVEL BED IN SECONDS

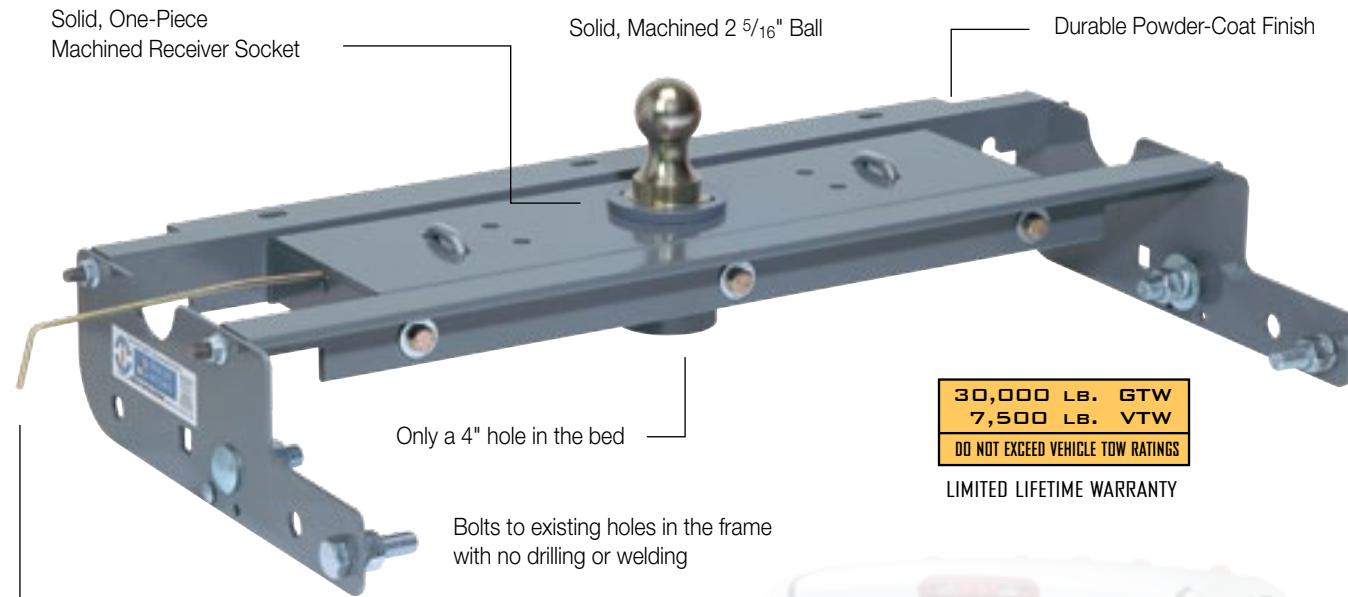

Flexible latch pin handle attached to a spring loaded, 5/8" steel locking pin that goes completely through the ball



Turnoverball™ Accessories



Kingpin



4" Extender

20,000 LB. GTW
5,000 LB. VTW
DO NOT EXCEED VEHICLE TOW RATINGS



Eyelet



Inverted Ball



3" Ball



Hi-Rise Ball
(1" taller than standard ball)

20,000 LB. GTW
5,000 LB. VTW
DO NOT EXCEED VEHICLE TOW RATINGS



Companion™
5th Wheel Hitch



Companion™ Slider
5th Wheel Hitch



Locking Coupler



Locks on...
or off your truck



Lock is fully integrated into coupler with a mechanical shutter to keep out debris.



The Coupler. Reinvented.

- **Integrated Lock**
Secures your investment with an integrated theft deterrent
- **Automatic Latch**
Line up the ball, drop the trailer, and you're on the road!
- **Heavy Wall Tubing**
Above industry standard
- **Increased Vertical Adjustment**
Extra hole for even more adjustment!

25,000 LB. GTW
7,500 LB. VTW
DO NOT EXCEED VEHICLE TOW RATINGS
LIMITED 1 YEAR WARRANTY



Large Bull's-eye
Cone shaped coupler makes lining up easier

Automatic Latch



Open handle to prepare for latching



Latch will engage automatically when lowered onto the ball



turnoverball.com

B&W Gooseneck Short Bed Solutions

MORE TURNING CLEARANCE FOR YOUR SHORT BED TRUCK.

*** WARNING:**

Turning clearance problems may be encountered when towing gooseneck trailers with short bed models.



4" Extender

OFFSETS BALL 4"

- An accessory to the Turnoverball™
- Moves pivot point rearward four inches
- Removable
- Made from 3/4" steel plate

20,000 LB. GTW
5,000 LB. VTW
DO NOT EXCEED VEHICLE TOW RATINGS

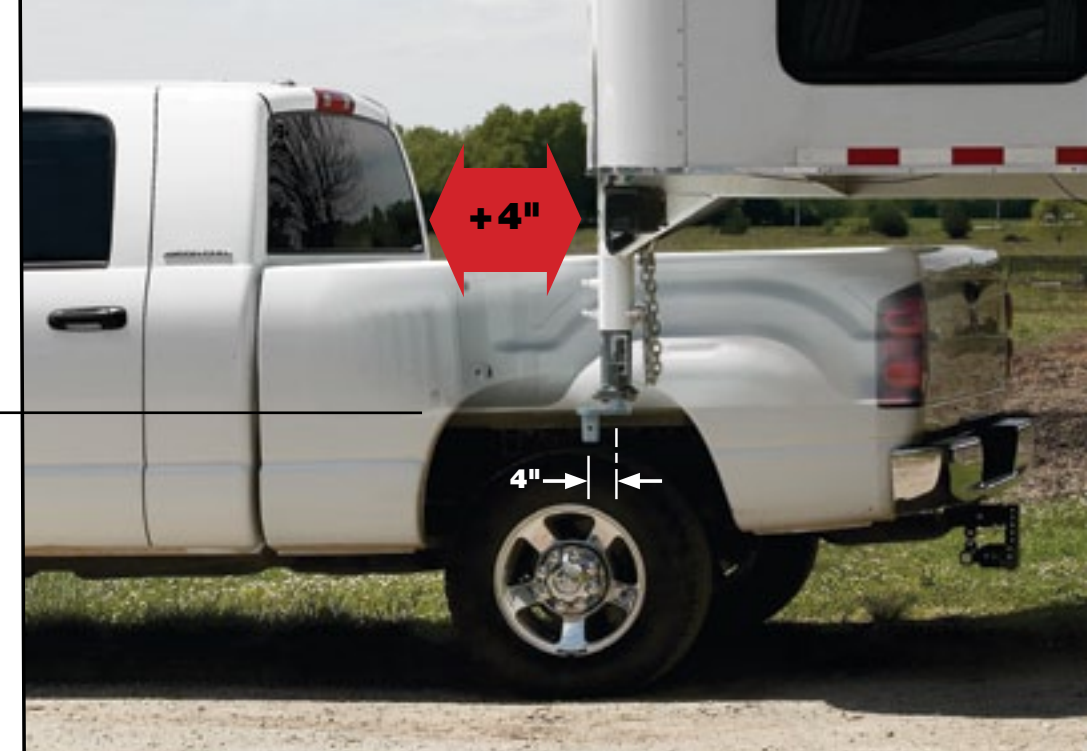

Extend-A-Goose

OFFSETS TRAILER 10"

- Self-aligning coupler design
- Heavy wall tube with internal gussets provide maximum strength
- Easier hook ups with more clearance at the tailgate and trailer
- Fits all standard 4" I.D. round trailer tubes
- Funnel shaped coupler assists in aligning the trailer with the hitch.
- Accommodates padlock for theft prevention

24,000 LB. GTW
6,000 LB. VTW
DO NOT EXCEED VEHICLE TOW RATINGS

LIMITED 1 YEAR WARRANTY

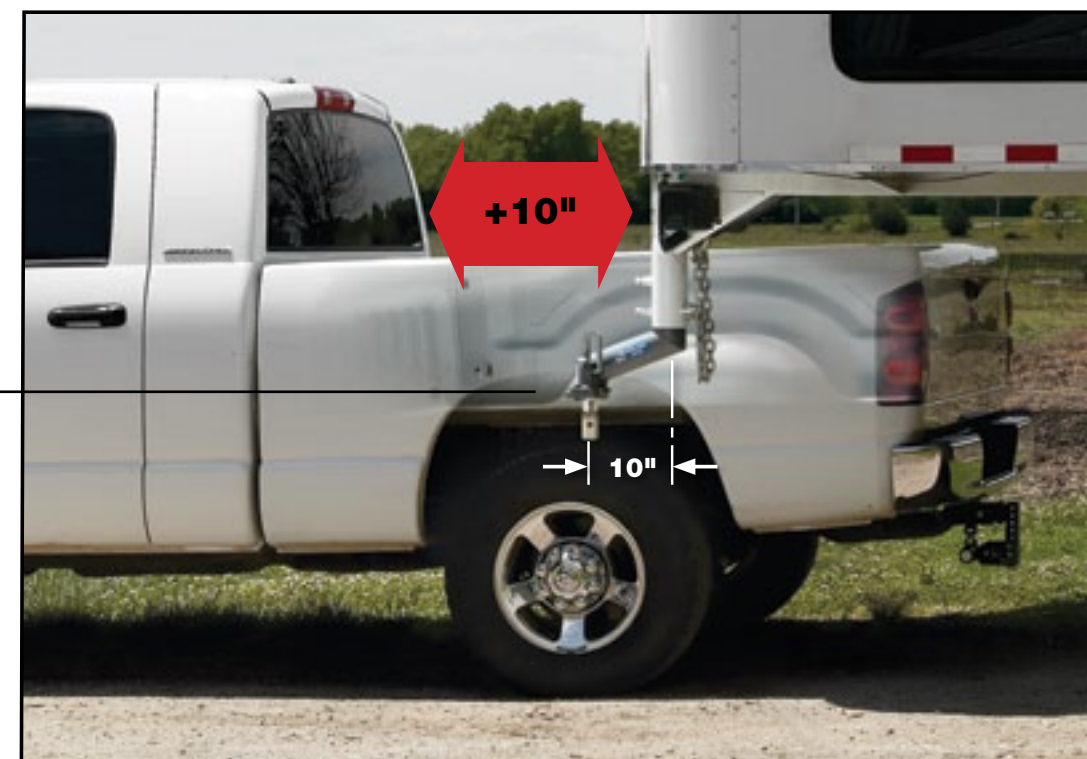
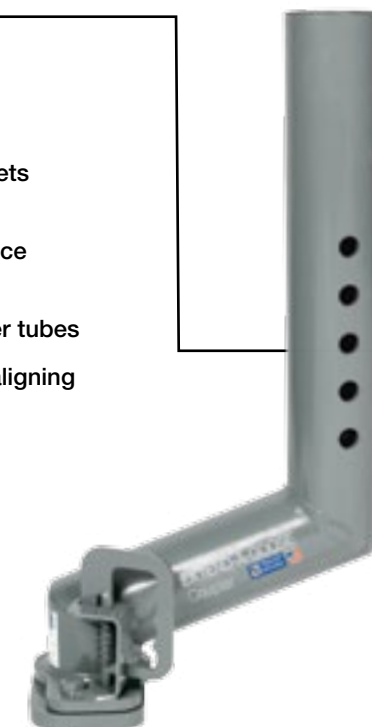



Which one is right for you?

The hitch may be small, but don't underestimate its importance. This engineered metal can make the difference between a comfortable ride and a nail-biter.

B&W Trailer Hitches developed a line of fifth-wheel hitches based on a single goal: create a smooth, worry-free ride.

RAILS.



The **Patriot 16K** is our answer to the rail mounted imports offered by our competitors. Designed as a less-expensive, lighter-weight alternative to its big brother, the Companion, with many of the same great features.

GTW 16,000 LBS. - VTW 4,000 LBS.

All standard rails including B&W's RVR3200.

- 3/4" thick.
-
-
- 16", 17", 18", 19".
- Leaf spring.
- 5 YEAR LIMITED WARRANTY**



NO RAILS.



The **Companion**, adored by RVers, was designed to address the issue of sloppiness in hitches. The result is a quiet, cushioned ride that is free of jerking. And it's removable. Free up your truck bed when you aren't towing.

GTW 20,000 LBS. - VTW 5,000 LBS.

B&W's under-bed mounting system, that also accommodates a gooseneck ball.

- 1" thick.
-
-
- 16 1/4", 17 1/4", 18 1/4".
- Shock absorber.
- 5 YEAR LIMITED WARRANTY**



SLIDE.



The **Companion Slider** took years to develop. We took our time, and did it right. It has an automatic latch in both directions, 12 inches of rearward travel and the same coupler as the original Companion. And it's removable.

GTW 18,000 LBS. - VTW 4,500 LBS.

B&W's under-bed mounting system, that also accommodates a gooseneck ball.

- 1" thick.
-
-
- 17", 18", 19".
- Shock absorber.
- 5 YEAR LIMITED WARRANTY**

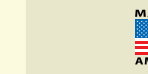

PUCKS.



The **Companion OEM** has all the things that you love about the Companion, but it's designed to work with the Ford factory platform. It's an alternative to the expensive version Ford offers. And it's removable. Now you have a choice!

GTW 20,000 LBS. - VTW 5,000 LBS.

Ford's factory installed hitch platform.

- 1" thick.
-
-
- 17", 18", 19".
- Shock absorber.
- 5 YEAR LIMITED WARRANTY**



FLATBED.



The **Companion Flatbed**. It's the Companion only smaller! The same coupler used on the Companion is attached to a low-profile base. It's designed to be used with steel flatbeds.

GTW 22,000 LBS. - VTW 5,500 LBS.

B&W's flatbed mounting system GNRK1500.

- 1" thick.
-
-
- No adjustment.
- Shock absorber.
- 5 YEAR LIMITED WARRANTY**





B&W
THE PATRIOT
16K BY **B&W TRAILER HITCHES**

5th Wheel Hitch SMOOTH TOWING FOR FIFTH WHEEL RV'S



Easy to Reach,
Cam Action Handle

Fully articulating head allowing
front-to-back and side-to-side
pivoting

4" of front-to-back adjustment
with three coupler positions

Four vertical adjustments
from 16" to 19"

Fits all Standard Mounting Rails

16,000 LB. GTW
4,000 LB. VTW
DO NOT EXCEED VEHICLE TOW RATINGS
 LIMITED 5 YEAR WARRANTY



3/4" wrap around jaws for a strong,
worry-free connection



Polyurethane bushings prevent
metal to metal contact.

Same Rails ... Better Hitch

- American Steel
- American Quality
- Priced like an Import

For the past ten years, fifth-wheel owners have spread the word about the B&W Companion Hitch and how well it tows. The Patriot 16K delivers the same tow with cam-operated locking jaws, polyurethane coated arms, and a rugged build, but priced to compete with imported hitches. Designed to upgrade the RVing experience, the Patriot is American-made.



Companion Slider
For your short bed truck



18,000 LB. GTW
4,500 LB. VTW
DO NOT EXCEED VEHICLE TOW RATINGS
LIMITED 5 YEAR WARRANTY

Companion OEM
For your Ford Prep Package



20,000 LB. GTW
5,000 LB. VTW
DO NOT EXCEED VEHICLE TOW RATINGS
LIMITED 5 YEAR WARRANTY

Companion Flatbed
For your steel flat bed truck



22,000 LB. GTW
5,500 LB. VTW
DO NOT EXCEED VEHICLE TOW RATINGS
LIMITED 5 YEAR WARRANTY

B&W Companion™ 5th Wheel Hitch

EASILY CONVERTS TO A LEVEL BED



Polyurethane bushings provide a quiet, rattle-free towing experience

Fully articulating head allows front-to-back and side-to-side pivoting

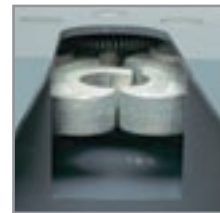

1" thick, wrap-around jaws fit kingpin perfectly, eliminating sloppy starts and stops

Three vertical adjustments from 16.25" to 18.25"

4" of front-to-back adjustment with three coupler positions

Cam action latching handle for easy release, even when parked on unlevel sites



Utilizes the B&W Turnoverball™ under-bed mounting system. Pull a Gooseneck or a 5th Wheel with the same system

20,000 LB. GTW
5,000 LB. VTW
DO NOT EXCEED VEHICLE TOW RATINGS
LIMITED 5 YEAR WARRANTY



Ever use your truck when you're not towing?

We thought you did!

INSTALLS & REMOVES EASILY



Companion™ Installed



Remove Coupler



Remove Base

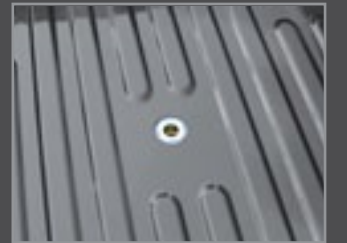

Use your truck bed for something else.



Need Room to Maneuver? Of course you do!

Extra room between your truck cab and 5th wheel to maneuver into that tough campsite.

We know what it's like to tow with a short bed truck! That's why we designed our slider RV hitch. With twelve inches of slide, it gives you the extra room to maneuver your fifth-wheel at those tight campsites. And it's a Companion so you'll love the ride.

B&W Companion™ Slider 5th Wheel Hitch

EXTRA CLEARANCE FOR SHORT BED TRUCKS

Cam-action latching handle for easy release, even when parked on unlevel sites

Fully articulating head allows front-to-back and side-to-side pivoting

Three vertical adjustments from 17" to 18" to 19".

12" of sliding movement, for turning and maneuvering clearance in short bed trucks.

This manual slider's automatic handle latches in both directions, meaning you only get out of the truck once to move into maneuvering position.

Utilizes the B&W Turnoverball™ under-bed mounting system. This single-point attachment method means you can pull a Gooseneck or a 5th Wheel, and have a level bed when not towing.

18,000 LB. GTW
4,500 LB. VTW
DO NOT EXCEED VEHICLE TOW RATINGS
LIMITED 5 YEAR WARRANTY

SLIDING FEATURES



12" of sliding movement for turning and maneuvering clearance in short bed trucks.



Tight tolerances in the sliding mechanism means smooth movement without the rattle.



Polyurethane bushings prevent metal to metal contact.

turnoverball.com



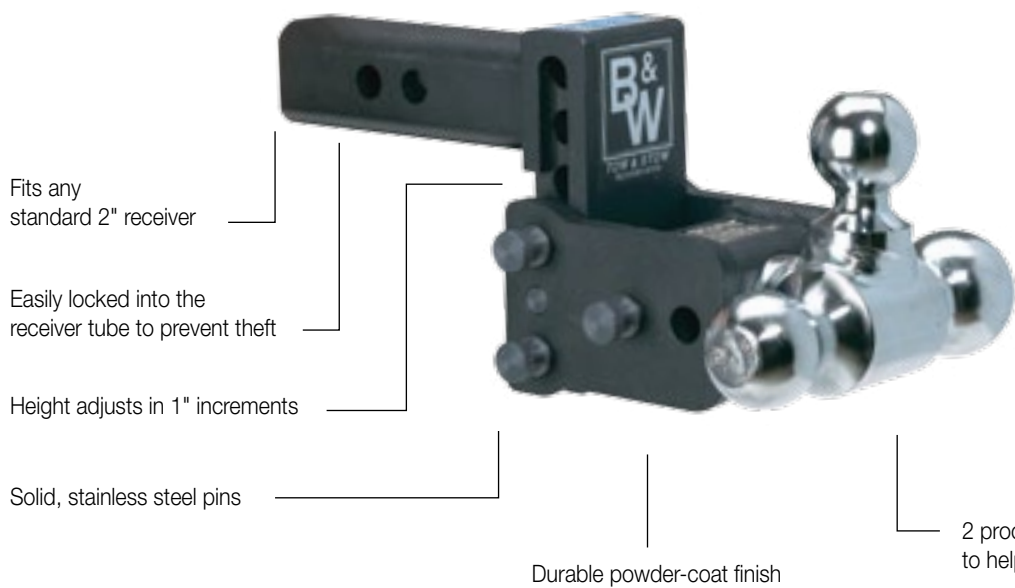

Fits any standard 2" receiver

Easily locked into the receiver tube to prevent theft

Height adjusts in 1" increments

Solid, stainless steel pins

Durable powder-coat finish
(Also available in chrome)

2 process plating to help prevent corrosion

B&W Tow & Stow

STOWS UNDER THE VEHICLE WHEN NOT IN USE

Multiple ball sizes eliminate the need for multiple ball mounts



MANUFACTURED FROM HIGH YIELD TUBING



Rotate the Ball
To the Desired Size



Adjust the Height
Raise or Lower

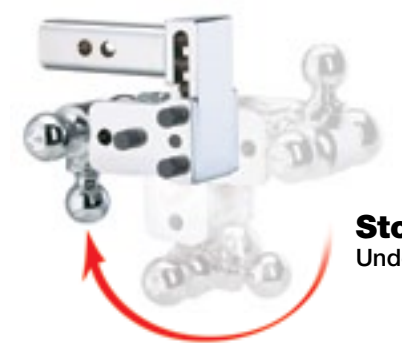

Stow the Hitch
Under the Vehicle

Available Drops



Available Ball Combinations



Tow & Stow hitches are available with the licensed Browning logo.



**B&W
Tow & Stow™
with Drop Down Pintle**



Pintle Up
Ready to hook on.



Pintle Down
Ready to tow.



Stowed
Ready to go.





B&W 16K Heavy-Duty Receiver Hitch

- Three Piece Interlocking Design
- Six Point Frame Mount
- Grade 8 Mounting Hardware
- Boxed for Product Protection and Easier Shipping



Durable, High Gloss Powder Coated Finish

Steel Gusset with Safety Chain Openings

2" Receiver Tube



Includes Trailer Plug Bracket

CLASS 16,000 LB. GTW
1,600 LB. VTW
DO NOT EXCEED VEHICLE TOW RATINGS
LIFETIME LIMITED WARRANTY

B&W AMERICAN MADE Heavy-Duty Towing Accessories



Heavy Duty Ball Mounts

High Gloss Powder Coat Finish

Part #	Drop	Shank
BMHD30010	2" Drop	6" Shank
BMHD30011	2" Drop	8" Shank
BMHD30012	4" Drop	6" Shank
BMHD30013	4" Drop	8" Shank
BMHD30014	6" Drop	6" Shank

CLASS 16,000 LB. GTW
1,600 LB. VTW
DO NOT EXCEED VEHICLE TOW RATINGS



Heavy Duty Pintle Plate

High Gloss Powder Coat Finish

Part #	Hole	Position	Shank
PMHD14001	6 Hole,	2 Position,	9" Shank
PMHD14002	8 Hole,	3 Position,	9" Shank
PMHD14003	8 Hole,	3 Position,	11" Shank
PMHD14004	14 Hole,	6 Position,	13" Shank
PMHD14005	14 Hole,	6 Position,	15" Shank

CLASS 16,000 LB. GTW
1,600 LB. VTW
DO NOT EXCEED VEHICLE TOW RATINGS



Hitch Balls

Specialty and Heat Treated

Heat Treated

Chrome Finish

Part #	Ball Diameter	Shank Diameter	Shank Length	Max Load	Rise	Threads Per Inch	Finish
HB94001	2-5/16	1	2-1/2	12K	No Rise	14	Heat Treated
HB94002	2-5/16	1-1/4	2-1/2	24K	1"	12	Heat Treated
HB94003	2-5/16	1-1/4	3-1/4	24K	1"	12	Heat Treated
HB94004	2-5/16	1-1/4	2-1/2	30K	No Rise	12	Heat Treated
HB94005	2-5/16	1-1/2	2-3/4	30K	1"	12	Heat Treated
HB94006	2-5/16	1-1/2	2-3/4	30K	2"	12	Heat Treated
HB94007	2-5/16	1-3/8	2-3/4	30K	1"	12	Heat Treated
HB94008	3	2	3-1/4	30K	No Rise	12	Heat Treated
HB94009	2-5/16	2	3-1/2	30K	No Rise	4.5	Heat Treated
HB94011	2-5/16	2-3/16	4	30K	No Rise	n/a	Heat Treated
HB94012	Ball Collar 2.199 ID		2" Tall				Untreated
HB94013	Ball Collar 2.199 ID		3" Tall				Untreated
HB94050	2-5/16	1-1/4	2-1/2	16K	No Rise	12	Chrome

Triple Tow Ball Mount

High Gloss Powder Coat Finish

BMTT31004 Triple Tow Ball Mount



CLASS 10,000 LB. GTW
1,000 LB. VTW
DO NOT EXCEED VEHICLE TOW RATINGS



turnoverball.com



B&W Cab Protectors

Built to protect. Designed to fit.

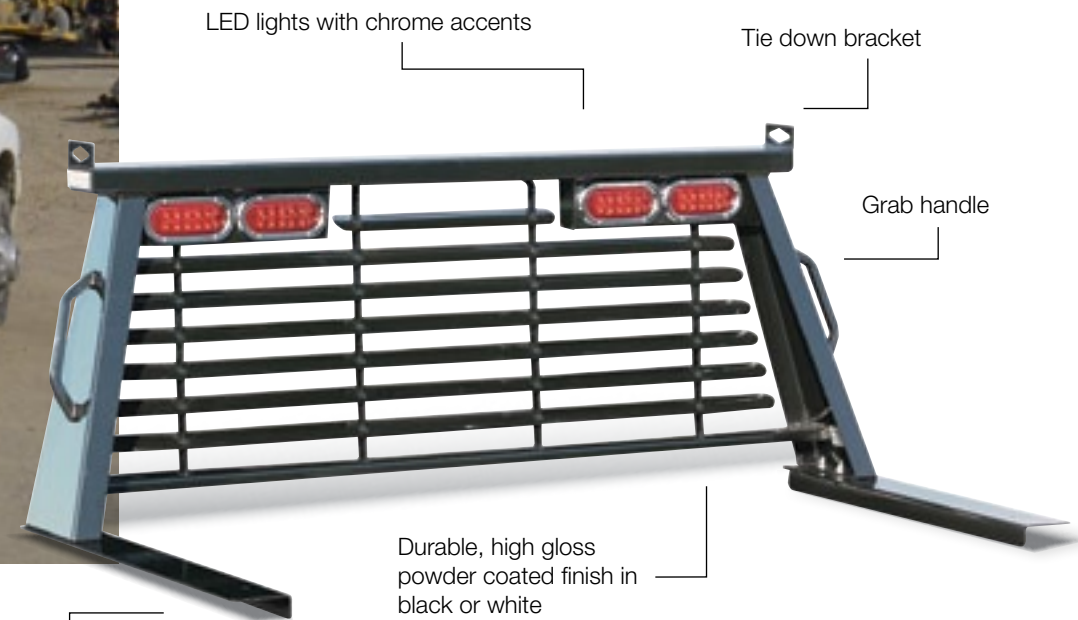

Truck specific for a perfect fit.



Optional
Beacon Light Bracket

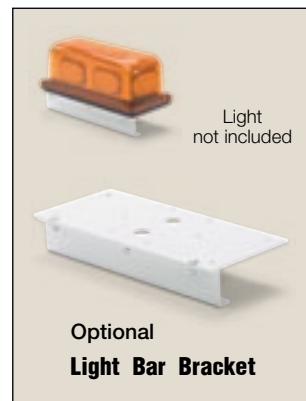

Optional
Light Bar Bracket

The cab protector and a glass window is all that stands between you and that heavy load of equipment in the bed of your truck. That's why B&W makes sure it's strong enough to protect your cab. But we couldn't overlook the way it makes the truck look. That's why it's designed to fit.

B&W Utility Rack

Removable rack for long and short bed trucks



Durable, powder coated finish

Rated to 500 LBS

Tie down brackets on all four corners

Easily adjusts to fit long or short bed trucks

Weight rests on bed rails not in stake pockets



Utilizes B&W Turnoverball™ Gooseneck Hitch for single point attachment



Maintains full use of truck bed.





B&W Trailer Hitches
1216 Highway 224
Humboldt, KS 66748
800-248-6564



turnoverball.com

